

Bohle – BRC 100

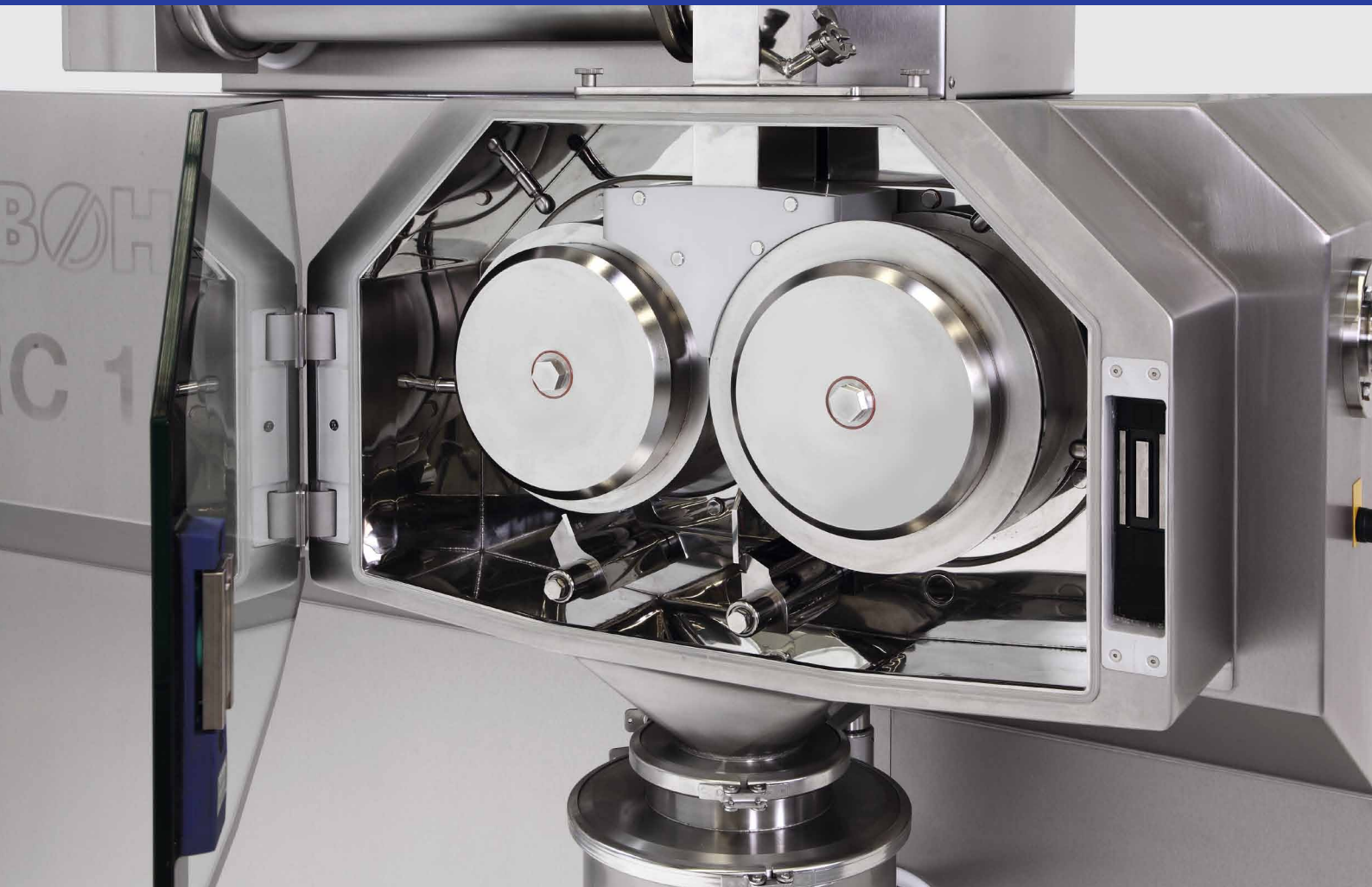



The pharmaceutical industry's demand for continuous processes is increasing because it offers clear advantages such as cost savings, process robustness and no scale-up hurdles. Continuous dry granulation is now often the process of choice for large-volume or moisture-sensitive products. L.B. Bohle meets this growing demand by offering the new Bohle BRC 100, an innovative variable gap dry granulator. With the introduction of the BRC 100, L.B. Bohle now serves customer needs for all available granulation techniques in the industry.

The BRC 100 enables high-production capacity with minimal loss of material. This is achieved by fast and precise control of the compaction force with a new electromechanical spindle drive for the two rollers. In combination with a sensitive control of the variable gap via the screw feeding system, constant ribbon properties are assured over a wide production range from <1 kg up to 200 kg/h.

Sophisticated equipment design facilitates easy handling and shortens mounting procedures during working shifts. A hygienic design and properly integrated cleaning nozzles allow an effective wash in place process (WIP).

The BRC 100 achieves ribbon granulation with the Bohle Turbo Sieve (BTS 200). The conical sieve design allows gentle particle size reduction at low sieve speeds, which is also applicable at high material throughputs. A variety of different sieve types make it flexible for different product and ribbon properties.

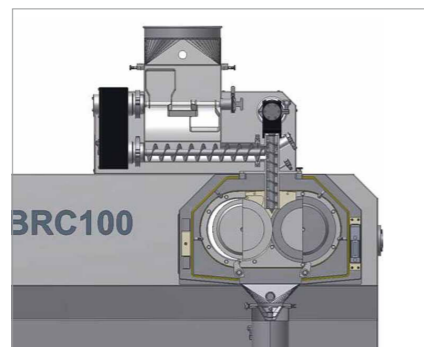

The BRC 100 meets Quality by Design requirements with its functional GMP design, as well as with its ability to implement different PAT tools.



Bohle – BRC 100

Capacity [kg/h]	≤1 – 200 kg/h (up to 400kg/h product dependent)
Specific compaction force [kN/cm]	0.5 – 20
Roller width [mm]	100
Roller speed [rpm]	1 – 30
Gap width [mm]	1 – 6
Sieve speed [rpm]	30 – 350
Size (W x L x H) [mm]	1750 (2300 incl. operator desk) x 1930 x 2140
Weight [kg]	Approx. 2300
Power supply	3 x 400V / PE / 50Hz / 21KW / 63A 3 x 460V / GND / 60Hz / 21KW / 63A (alternative)
Operator panel	Siemens Touch Panel
Qualification	DS, FS, DQ, IQ, OQ
21 CFR part 11 compliance	Electronic records
Computer validation	According GAMP 5 guideline

Bohle – BRC 100

The advantages of the new Bohle – BRC 100

- Minimal material loss due to precise control of the compression force with an innovative electromechanical roller drive
- Constant ribbon properties assured with sensitive gap width control
- Easy handling and short mounting procedures
- Hygienic design and effective cleaning by integrated WIP nozzles
- Versatile and gentle particle size adjustment with integrated Bohle Turbo Sieve (BTS 200)
- PAT tool integration possible



L.B. Bohle
Maschinen + Verfahren GmbH
Industriestraße 18
59320 Ennigerloh
Germany
Tel.: +49 2524 9323-0
Fax: +49 2524 9323-29

E-Mail: info@lbbohle.de
Internet: www.lbbohle.de